

Model CR103J

DC Current and Voltage Calibrator/Standard

$\pm 0.01\mu A$ to $\pm 111.1110mA$

$\pm 0.1\mu V$ to $\pm 11.11110V$



**KH KROHN-HITE
CORPORATION**

Operating Manual

This page intentionally left blank.

CR103J
OPERATORS
MANUAL

Serial No. _____

This page intentionally left blank.

CR103J OPERATORS MANUAL



Copyright © 1999

Electronic Development Company
15 Jonathan Drive Unit 4
Brockton, Massachusetts 02301
E-mail: Info@krohn-hite.com
www.krohn-hite.com

All rights reserved. No part of this publication may be reproduced, stored in a retrieval system or transmitted in any form by any means, electronic, mechanical, photocopying, recording, or otherwise, without the prior written permission of Electronic Development Company.

Printed in U.S.A.
Revised April 1999

Information furnished in this manual is believed to be accurate and reliable. However, no responsibility is assumed by Electronic Development Company for its use; nor for any infringements of patents or other rights of third parties which may result from its use.

TABLE OF CONTENTS

<u>SECTION</u>	<u>TITLE</u>
i	List of Drawings
ii	Warranty
iii	Factory Service Request and Authorization
iv	Packing Suggestions
I	DESCRIPTION AND SPECIFICATIONS
1.1.0	General Description and Application
1.2.0	Current Mode Specifications
1.3.0	Voltage Mode Specifications
1.4.0	General Specifications
II	INSTALLATION
2.1.0	General Information
III	OPERATION OF THE INSTRUMENT
3.1.0	Front Panel Control
3.2.0	Front Panel Indicators
3.3.0	Operation as a Voltage Source
3.4.0	Operation as a Current Source
3.5.0	Optional Current range Compliance Voltage Limit Switch
IV	THEORY OF OPERATION 
4.1.0	Introduction
4.2.0	Power Supply
4.3.0	Internal Precision Reference
4.4.0	Chopper Stabilized Amplifier
4.5.0	Feedback
4.6.0	Output selector
4.7.0	Overload circuitry
4.8.0	Voltage Source
4.9.0	Current Source
V	MAINTENANCE
5.1.0	Preventive Maintenance
VI	CALIBRATION
6.1.0	Voltage mode calibration
6.2.0	Current mode calibration
VII	PARTS LIST
7.1.0	Replacement Parts for CR103J
<u>NOTE:</u>	Errata and addendum (if any) will appear in the back of this manual.

LIST OF DRAWINGS

DESCRIPTION	DRAWING #
Block Diagram	A4387
Calibration Adjustments	CB4688-B
Layout Voltage Board	CB4686-B
Layout Current Board	B4376 Rev. B
Power Supply	B2918-5
Current Amplifier	B2917 Rev. L
Voltage Amplifier	B2916-4
Reference Drawing	930727A

LIMITED WARRANTY

The ELECTRONIC DEVELOPMENT Company (E.D.C.) warrants to the original purchaser that each instrument manufactured by them to be free from defects in material and workmanship. This warranty is limited to servicing, repairing and/or replacing any instrument or part thereof returned to the E.D.C. factory for that purpose in accordance with the instructions set forth below; and furthermore to repair or replace all materials, which shall, within ONE YEAR of shipment to the original purchaser, be returned to the E.D.C. factory, and upon examination, be deemed defective.

E.D.C. instruments may not be returned to the factory under the terms of this warranty without the prior authorization of the E.D.C. Service Department. All instruments returned to E.D.C. for service hereunder should be carefully packed and shipped. All transportation charges shall be paid by the purchaser.

EDC reserves the right to discontinue instruments without notice and to make changes to any instrument at any time without incurring any obligation to so modify instruments previously sold.

This warranty is expressly in lieu of all other obligations or liabilities on the part of EDC. No other person or persons is authorized to assume in the behalf of EDC any liability in the connection with the sale of its instruments.

NOTICE: Instruments that have been calibrated and certified will be sealed. Removal of this seal without the expressed permission of E.D.C. or any attempts to repair, modify or otherwise tamper with the instrument by anyone other than an EDC employee or authorized representative will void the certification and may void the warranty.

Warranty repairs are guaranteed for the balance of the Warranty period or up to 90 days from the date of the return shipment, whichever is later.

FACTORY SERVICE REQUEST AND AUTHORIZATION

WARRANTY SERVICE

Instruments may be returned only on prior authorization. Please obtain a RETURN AUTHORIZATION NUMBER either directly from the factory or from an authorized E.D.C. Representative. (See General Information below.)

CHARGEABLE REPAIRS

If requested, an estimate of charges will be submitted prior to repairs. We suggest that you request a RETURN AUTHORIZATION NUMBER to facilitate handling.

GENERAL INFORMATION

- A) Please provide the following information in order to expedite the repair:
 - 1) Indicate MODEL
 - 2) Serial Number
 - 3 Complete description of the trouble:

Symptoms, measurements taken, equipment used, lash-up procedures, attempted repairs, suspected location of failure and any other pertinent information.
- B) Freight Charges must be PREPAID.
- C) The RETURN AUTHORIZATION NUMBER should be noted on your documentation.

PACKING SUGGESTION

Although your E.D.C. instrument is built for laboratory, production environment and some field environment, it is NOT ruggedized. Therefore . . .

1. Be sure the carton is **STRONG** enough to carry the weight of the instrument, e.g. use double wall corrugation.
2. Be sure the carton is **LARGE** enough to allow for sufficient packing material, e.g., at least 2 inches all around the instrument. The packing material should be able to be compressed and then return to its approximate original volume.
3. For better handling, the shipment should always be by **AIR FREIGHT** (except for short distances). You might use either UPS "blue label" or common air freight carrier, second day air.

Please do not bounce it across the country in a truck. It may not hurt it, but it certainly is not going to do a laboratory instrument much good.

4. **QUESTIONS?** Just contact us. We will be pleased to help you.

SECTION I

1.0.0 GENERAL DESCRIPTION AND SPECIFICATIONS

1.1.0 General Description

1.1.1 The Model CR103J is a versatile combination of a high accuracy DC current source, a high accuracy DC voltage source and calibrator, combined in one instrument.

1.1.2 The unit is laboratory calibrated against a primary measuring system, having an absolute error of less than 10 ppm. The saturated standard cells used are certified, and are traceable to the U. S. National Institute of Standards and Technology formerly National Bureau of Standards, having a long history of documented stability.

1.1.3 Current and voltage calibrator controls are obtained through front panel rotary and decade switches.

No adjustments are required between calibration cycles. Adjustment settings are made at final calibration and are fully described under calibration procedures.

1.1.4 The circuitry is completely solid state packaged in discrete, hybrid and integrated circuit modules. These are proven circuits, using derated components to insure maximum reliability. Major discrete circuits are packaged on etched glass epoxy boards, so that the instrument can withstand abnormal environmental conditions. The instrument is also overload and short circuit protected.

1.2.0 Current Mode Specifications

1.2.1 All measurements are based on a 100 ohms Standard Resistor.

1.2.2 OUTPUT

100 mA Range	± 111.1110 mA
10 mA Range	± 11.11110 mA

1.2.3 RESOLUTION	1 ppm
100 mA Range	0.1 μ A
10 mA Range	0.01 μ A

1.2.4 OUTPUT ACCURACY (2 Methods)

Calibration Accuracy:
 $\pm(0.005\%$ of setting $+0.0005\%$ of range)

The calibration accuracy is at Standard Reference Conditions at time of calibration. Nominal calibration temperature of $23^{\circ}\text{C} \pm 1^{\circ}\text{C}$ at 70% Humidity. Nominal line voltage 117 Vac at constant external load.

Limit of error Method:
 $\pm(0.01\%$ of setting $+0.001\%$ of range)

SPECIAL NOTE:

Basis for Accuracy Statement: Calibration Accuracy 15 ppm R.S.S. of tolerance of primary calibration system. *Accuracy (Limit of Error or "Worst Case" Method) based on 4:1 calibration ratio to the primary calibration system. All peripheral, additive specs, i.e., error for line change, load change, temperature change, drift and noise are included in "Limit of Error" and are designated as *NON-ADDITIVE. Normal operating environment 65° to 85° F 70% R.H.

1.2.5 Stability * (non-additive)

1 hour	$\pm 0.001\%$
8 hours	$\pm 0.003\%$
1 year	$\pm 0.005\%$

1.2.6 Ripple and Noise, rms. *(non-additive)
(0.1 Hz to 100 kHz) 75 nanoamperes

1.2.7 Compliance Voltage

100 mA Range:	0 to 60 VDC
10 mA Range:	0 to 110 VDC

1.2.8 Load Regulation *(non-additive)
0.001% for 100% compliance change. 10% load to full load.

1.2.9 Output Conductance
0.1 microseimens

1.3.0 Voltage Mode Specifications

1.3.1 OUTPUT

10 V Range	$\pm 11.111\ 10\ V$
1 V Range	$\pm 1.111\ 110\ V$
100 mV Range	$\pm 111.111\ 0\ mV$

1.3.2 RESOLUTION 1ppm

10 V Range	10 μV
1 V Range	1 μV
100 mV Range	0.1 μV

1.3.3 OUTPUT ACCURACY (2 Methods)

Calibration Accuracy:
 $\pm(0.003\% \text{ of setting} + 0.0005\% \text{ of range} + 3\ \mu V)$.

At Standard Reference conditions (See Current Mode for definitions).

Limit of Error Accuracy:
 $\pm(0.005\% \text{ of setting} + 0.00075\% \text{ of range} + 3\ \mu V)$.

At Limit of Error or "Worst Case" conditions. (See Current Mode for definitions).

1.3.4 Stability *(non-additive)

1 hour	$\pm 0.00075\%$
8 hours	$\pm 0.001\%$
1 year	$\pm 0.005\%$

1.3.5 Ripple and Noise, rms * (non-additive) (0.1 Hz to 100 kHz)

10 V Range	50 μV
1 V Range	40 μV
100 mV Range	5 μV

1.3.6 Output Current

10 V and 1 V Rang	50 milliamperes
100 mV Range	EMF into 100 K Ω load. See output impedance)

1.3.7 Load Regulation *(non-additive)

$\pm 0.0005\%$ No load to full load.

1.3.8 Output Impedance
10 V & 1 V Range 0.03Ω
100 mV Range 3Ω (Constant)

1.3.9 Line Regulation * (non-additive)
± 0.00055 for 10% line change.

1.4.0 General Specifications

1.4.1 Temperature:
Calibration Temperature 23° C + 1° C
Ambient Temperature 20° C to 30° C
Operating Limit -10° C to 50° C
Storage Temperatures -40° C to 85° C

1.4.2 Temperature Coefficient:
Ambient ± 0.0005%/° C
Operating Limit ± 0.001%/° C

1.4.3 Power Requirements:
50 watts, 50-400 Hz, 105-125 VAC
50 watts, 50-400 Hz, 220-240 VAC

1.4.4 Dimensions:
Bench:
5¼ x 17" X 10.9" (133.35 x 431.8 x 277 mm)

Rack Mounting (Option RK-02)
5¼ x 19" x 10.9" (133.35 x 482.6 x 277 mm)

Weight: 12 pounds (5.445 kg)

Shipping Weight: 15 pounds (6.795 kg)

1.4.5 Circuit Condition Indicator

Front panel indicator illuminates for short circuit, overload, over-voltage condition, low-line voltage or malfunction.

1.4.6 Protection
Short circuit, open circuit, and overload protection. Automatic recovery.
Over-voltage protection up to 150 V.

SECTION II

2.0.0 INSTALLATION

2.1.0 General Information

- 2.1.1 The instrument is available in rack version, designed for mounting in standard 19" racks. It is completely enclosed in dust covers and therefore suitable for bench top use. Resilient feet and a folding tilt bale are supplied. Order for rack mounting if desired.
- 2.1.2 The overall size is 5¼" high x 19" wide x 12" back of the panel. It weighs 12 pounds. A standard 3 prong polarized plug and power cable is attached, and the unit is ready for use.

Power Requirement = 50 Watts

Line Voltage Range 115 or 230 V 50/60 Hz

- 2.1.3 A two position slide switch is mounted on the rear panel which is used to set the line voltage requirements to 115 Vac or 230 Vac. Make sure this switch is in the proper position for your line power prior to turning the instrument on for the first time.
- 2.1.4. The instrument has been designed to be easily transported from one location to another and will be in a stable and accurate operation condition in less than one minute from turn on time.

SECTION III

3.0.0 OPERATION OF INSTRUMENT

3.1.0 Front Panel Controls

- 3.1.1 Power Switch:Rocker off-on, line power.
- 3.1.2 Polarity Switch: This switch has 3 settings with the polarity switch on "+" the red output terminals are positive with respect to the black terminals. On "-" the red output terminals are negative with respect to the black terminals. On "0" a short circuit exists between the red and black voltage output terminals, the current terminals are open circuit.
- 3.1.3 Voltage Output and Sense Terminals: 4 terminals are provided for output and sense. The red terminals represent the polarity with respect to the black as the common terminals. The red terminals are indicated by the polarity switch.
- 3.1.4 If a high impedance or a low current load is connected, the output and sense terminals may be shorted with the sense links (provided) e.g. plus output to plus sense.
- 3.1.5 When drawing relatively large amounts of current in the voltage mode, or if the load is far from the source, the remote sense capability should be used. The advantage of remote sense is that you have a 4 wire output and the sense lines are brought directly to the load, thus eliminating the IR drop of the output lines.
- 3.1.6 The metal terminal is case ground.
- 3.1.7 Current Output Terminals: A red and a black binding post is provided for the current source output. Polarity is the same as the voltage terminals.
- 3.1.8 With the range switch in a current position a load or a short should be placed across the current output terminals to prevent the full compliance voltage from appearing at these terminals.
- 3.1.9 Decade Switches: The decade switches are used to select the desired output.
- 3.1.10 Range Switch: The range switch is used to manually select one of the 5 range modes. In the two current ranges, the output and sense terminals at the right of the instrument are disconnected from the internal circuitry.
- 3.1.11 In the 3 voltage ranges the current terminals at the left of the instrument are shorted internally.

3.2.0 Front Panel Indicators

3.2.1 Overload lamp: This lamp will be on during initial power on. It should turn off after a few seconds. This lamp is used to indicate failure in the chopper stage. Refer to section 4.7.0 of the manual.

3.3.0 Operation as a Voltage Source

3.3.1 With power switch off, connect power cord to recommended power source, e.g. 115 VAC 60 Hz or 220 VAC 50 Hz. (See paragraph 2.1.3.)

3.3.2 Connect the output terminals of the instrument to their respective loads as required, observing the sensing rules (see drawing #930727)

NOTICE: THE SENSING CIRCUIT MUST BE COMPLETE

Please refer to **DRAWING #930727**, in the rear of this manual, for the two wire and four wire connections.

CAUTION

Do not place more than a 500 volt potential between the output terminals and chassis ground when using a floating output. In some applications it may be necessary to isolate chassis from line common. This practice is not recommended.

3.3.5 With polarity switch on "0" position, place power on switch to the "On" position. This procedure will prevent any possible turn on transient from appearing across the output terminals.

3.3.6 Select the desired output voltage on the decade switches, set range switch to appropriate range, and switch the polarity switch to required polarity.

3.4.0 Operation as a Current Source

- 3.4.1 With power switch off, connect power cord to recommended power source, e.g. 115 VAC 60 Hz or 220 VAC 50 Hz. (See paragraph 2.1.3.)
- 3.4.2 Connect the current output terminals of the instrument to their respective loads as required

CAUTION

This unit is capable of Compliance voltages in excess of 100 Volts.

Place polarity switch to "0" position whenever connecting or disconnecting the load to the current output terminals.

- 3.4.3 With polarity switch on "0" position, place power on switch to the "On" position. This procedure will prevent any possible turn on transient from appearing across the output terminals.
- 3.4.4 Select the desired output current on the decade switches, set range switch to appropriate current range, and switch the polarity switch to required polarity.

3.5.0 Optional Current range Compliance Voltage Limit Switch

- 3.5.1 This option is used to limit the amount of compliance voltage available in the current ranges.
- 3.5.2 On the rear panel is a six position rotary switch which is used to set the maximum compliance voltage.
- 3.5.3 Switch positions; 1-6, corresponds to open circuit voltages of 6.3V, 20V, 30V, 40V, 80V and the maximum compliance voltage. With the switch set to position 6, the compliance limit circuit is disabled.
- 3.5.4 This control should be set prior to operating the instrument.
- 3.5.5 The accuracy specs are not degraded by the limiting of the compliance voltage.

NOTE: With the compliance voltage switch set to positions 1-5, no "overload" indication will be present when a lower compliance voltage limit is exceeded.

- 3.5.6 The table below shows the typical useable compliance voltages for each switch setting.

Switch Position	Typical Usable Compliance Voltage	Nominal maximum Open Circuit Voltage
1 (minimum)	6.3 V	6.3 V
2	20V	20V
3	30V	30V
4	40V	40V
5	80 V	80 V
6 (maximum)	100 V	170 V

SENSE CONNECTIONS

HIGH CURRENT LOAD

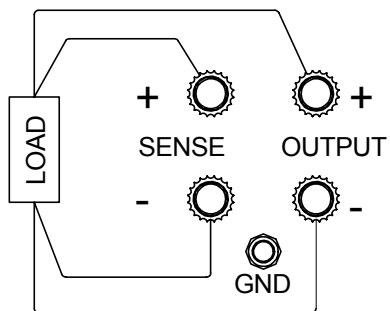
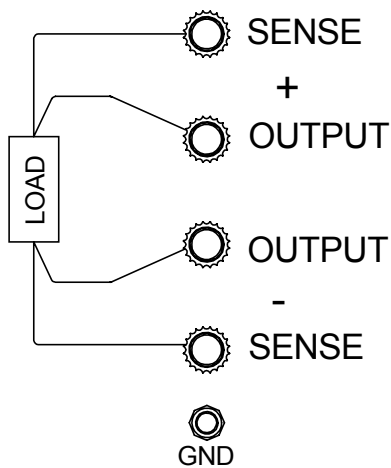

[Sense Links Removed]

FIG 1

LIGHT LOAD

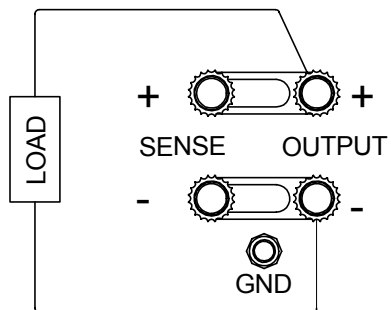
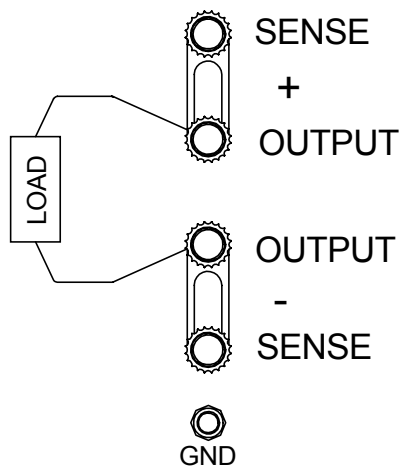

[Sense Links Installed]

FIG 2

OUTPUT CONNECTOR PIN FUNCTIONS

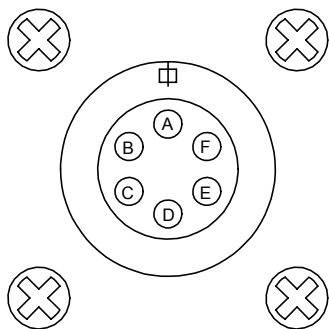

- PIN A Chassis Ground
- PIN B + Output
- PIN C - Output
- Pin D Not Used
- Pin E - Sense
- Pin F + Sense

FIG 3